

**SENTINEL
30/35
SERVICE
MANUAL**

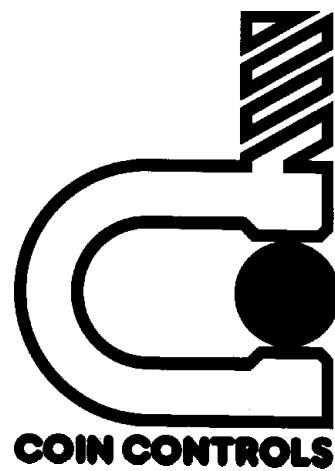

CONTENTS AND INTRODUCTION

Page No.

1	1.0	General Description
2	2.0	Sentinel Versions 30 and 35
3	3.0	Interface Connections
4	4.0	Sentinel Mechanical Description
4	4.1	Factory Fitted Coin Entry and exit options
4	4.2	Front Entry
4	4.3	Top Entry
5		Sentinel Exploded diagram
6	5.0	Coin Sorting
6	5.1	Coin Sorter Module
6	5.2	Removal and Replacement of Sorter
7	6.0	Mechanisms Internal Access
7	7.0	Mechanism Removal and installation in Machine
7	8.0	Electrical Interface Specification
7	8.1	Power Supply
7	8.2	Parallel Interface
7	9.0	Using the Parallel Interface
8	10.0	Routine Maintenance
8/9	11.0	On Site Testing

General Description

The Sentinel coin mechanism is the first of a new family of products based on Coin Controls' new cash handling concept of Flexible Cash Modules. It uses the latest in coin handling technology to offer a product with an unparalleled combination of performance, features and value for money.

The key feature of Sentinel is flexibility. By selection from the carefully designed system of mechanical sub-modules, Sentinel can be configured to suit any 5" size coin mechanism application.

Sentinel has the following features:-

Standard 5" size

Up to 8 coin validation

Industry standard parallel interface with automatic selection

IIC serial communication port

Field programmability of active 4 way sorter routing.

Coin output configuration compatible with existing AWP's when one of two optional manifolds are fitted.

Sentinel Versions 30 and 35

There are two versions of the Sentinel 30 series of coin acceptors. These are the Sentinel 30, which does not have a sorter, and the Sentinel 35 which has a full 4 way active sorter fitted.

Both versions are available with either Front Entry or Top Entry options. The Front Entry option is available with direct or indirect reject the Top Entry being available with Indirect reject only.

The versions in common usage are shown in Figures 1 to 5 below.

FIGURE 1 SENTINEL 30 TOP ENTRY

This shows the Top Entry version without the active sorter, for back channel mounting. This version may be used in Juke Boxes and vending applications where no coin sorting for payout is required and where front panel space is limited.

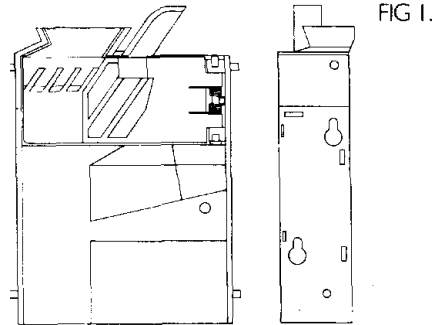
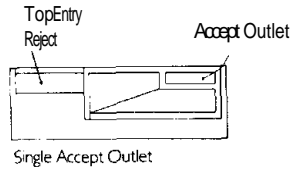

FIGURE 2 SENTINEL 35 TOP ENTRY

This shows the Top Entry version fitted with the active 4 way sorter, which may be site programmed. Applications for this version include vending with change.

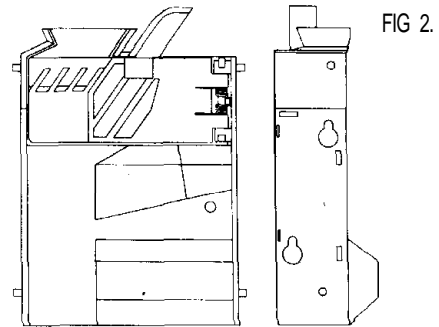
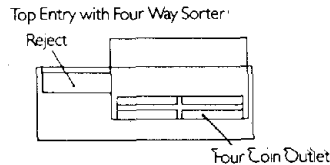

FIGURE 3 SENTINEL 30 FRONTPLATE, INDIRECT REJECT

This is the Front Entry version without the active sorter, and may be in either direct or indirect (machine) reject options. Applications for this version include Juke boxes, Vending and Video machines where front panel space is available.

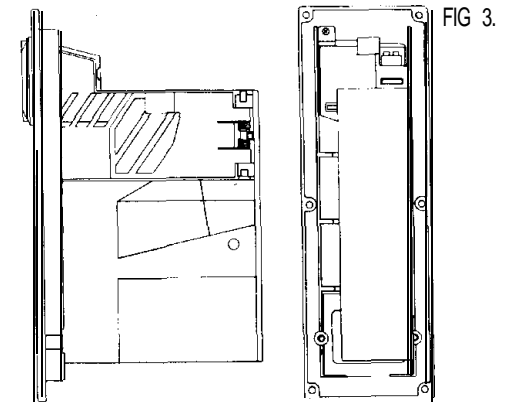

FIGURE 4 SENTINEL 35 FRONTPLATE, DIRECT REJECT

This is the Front Entry version fitted with the active 4 way sorter, and may be in either direct or Indirect (machine) reject options. Applications for this version include AWP, SWP and vending with change.

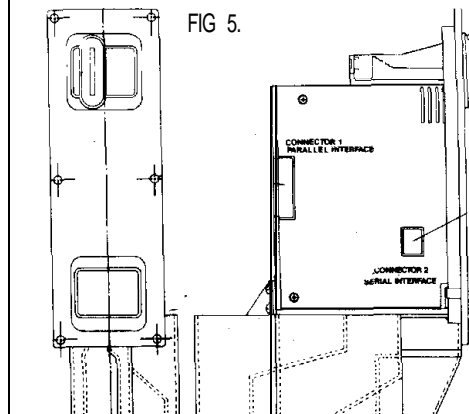
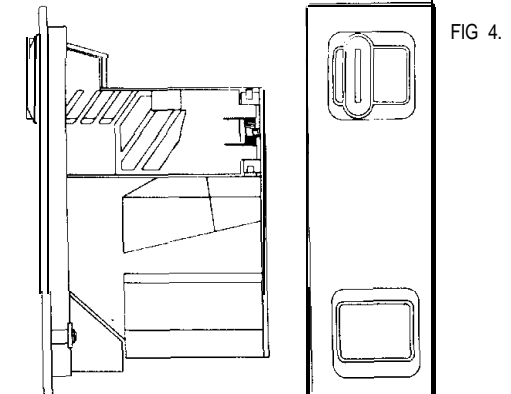
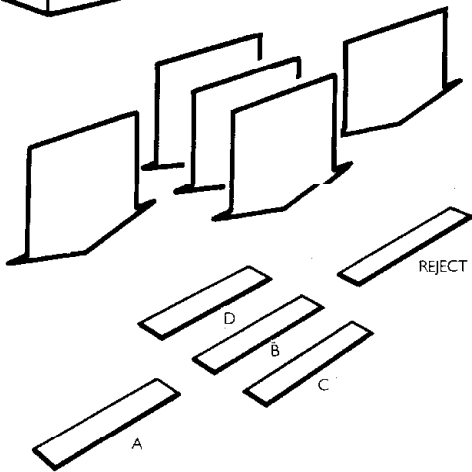
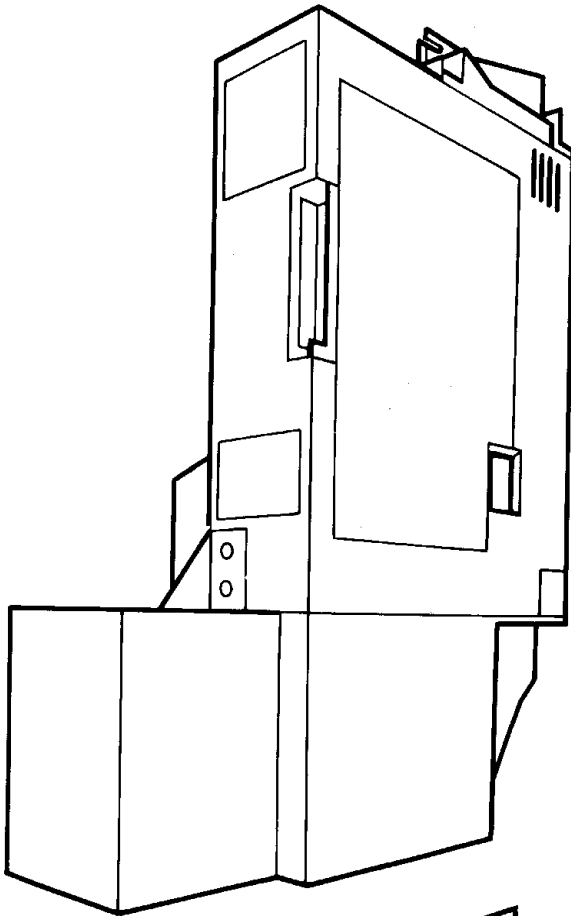

FIGURE 5 SENTINEL 35 FRONTPLATE, INDIRECT + MANIFOLD

This is the Front Entry version with active 4 way sorter fitted, with the addition of a manifold. This version will be found in current AWP and SWP machines. This version is available in indirect reject only. Two versions of the manifold are available and are shown in figure 6.

FIG 6.
Manifold 5 and 6 configurations

MANIFOLD 5



MANIFOLD 6

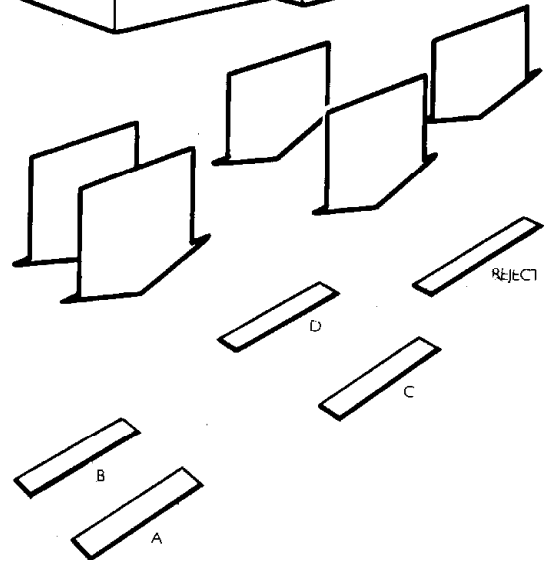
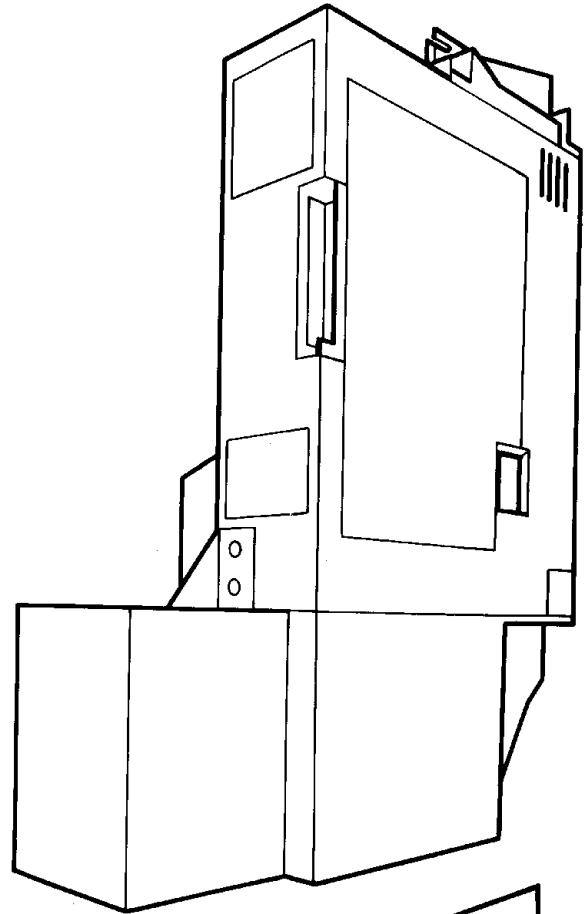

SENTINEL EXPLODED DIAGRAM

FIG 7

Parts List

- | | | |
|---------------------------------|-----------------------------------|---------------------------------------|
| 1 Coin entry and button housing | 21 Main body pole piece | 38 Sorter solenoid cover |
| 2 Button | 22 P.C.B. cover plate | 39 Coin rundown and reject cover |
| 3 Button lid | 23 Solenoid assembly | 40 Accept gate |
| 4 Button cone spring | 24 Hinge pin spring | 41 Accept gate spring |
| 5 Button label | 25 Main body snubber | 42 Reject gate |
| 6 Quick release latch | 26 Hinge pin | 43 Mech. mounting studs |
| 7 Main body | 27 Sorter coin diverter flap | 44 Front plate |
| 8 M4.0 x 16.0 pozi pan HD screw | 28 Final accept coil assembly | 45 M3.0 x 6.0 pozi pan HD screw |
| 9 Front entry gate piece | 29 Printed circuit board assembly | 46 Cotton catch |
| 10 Gate snubber | 30 4.20 x 5/8 pozi pan HD screw | 47 Photo Cells |
| 11 4.20 x 3/8" pozi CSK screw | 31 Sorter centre plate | 51 Top entry chute |
| 12 Quick release latch spring | 32 Coin diverter flap spring | 52 Top entry gate piece |
| 13 Front entry | 33 Sorter solenoid flap | 53 Top entry reject lever |
| 14 2nd sense coil assembly | 34 Solenoid flap pole piece | 54 Top entry reject lever pivot screw |
| 15 Bulb | 35 6.20 x 1/4" pozi pan HD screw | 55 Top entry reject lever spring |
| 16 Lamp holder | 36 Solenoid coin flap assembly | 56 Reject cup |
| 17 M4.0 full nut | 37 Sorter solenoid cone spring | 57 Reject cup flap |
| 18 1st sense coil assembly | | 58 M3.0 x pozi pan HD |
| 19 4.20 x 5/16" pozi pan HD | | 59 Single coin outlet |
| 20 3rd sense coil | | |

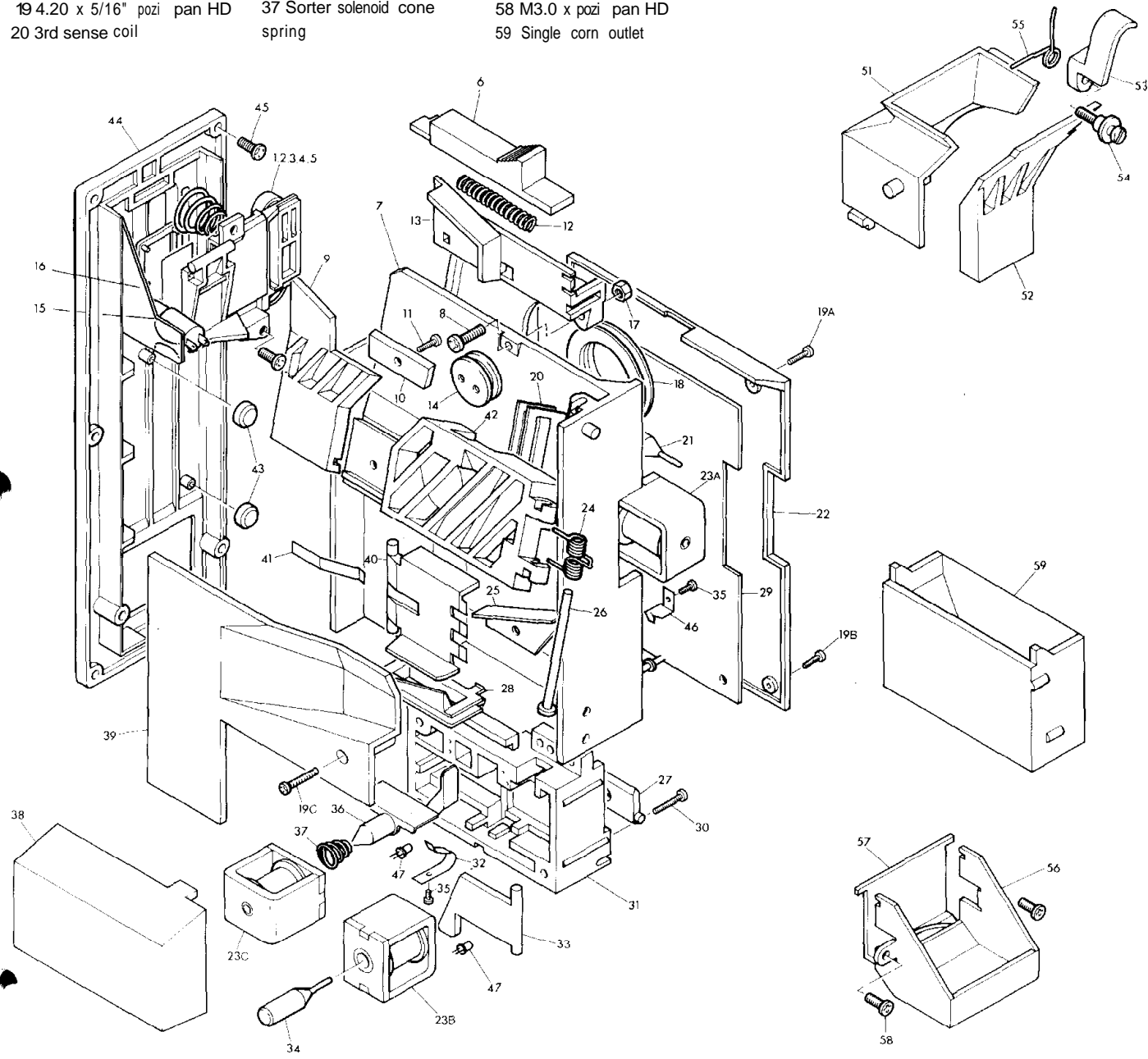

MECHANICAL DESCRIPTION

3.0 **Interface Connections**

All versions of the Sentinel 30/35 acceptor have the Universal Parallel interface (connector 1) for connection to any AWP, as well as the IIC serial interface (connector 2) for future use. The power supply to all versions is 12V DC — see Electrical Interface, section 8.

NOTE:

Pin 6 is used on Sentinel (SELECT — Low for 8-coin mode) and that no voltage greater than 5V should be applied to this pin.

4.0 **Sentinel Mechanical Description**

The Sentinel coin acceptor mechanical construction is shown in Figure 7.

A rundown is provided between the reject gate (42) and the body (7), along which are placed three coils of different shapes and sizes. The first coil (18) is a large diameter round coil which is placed at the front of the rundown. Coin no.2 is a small round coil (14), which is situated in the gate (42), and the final coil is a wrapround (20).

If a coin, having passed the three sensors, is deemed true, the accept gate (40) is opened by energising a solenoid (23A) and the coin passes through the accept coil (28). Having cleared the accept coil, the accept gate is closed and a credit signal is generated.

If the mechanism is fitted with a sorter, this is energised at the same time as the accept flap and is reset once the photo cells (47) have detected the accepted coin leaving the sorter outlet.

4.1 **Factory Fitted Coin Entry and exit options**

4.2 **Front Entry**

The front entry option is achieved by fixing to the basic assembly part numbered (6, 8, 9, 12, 13, 15, 16). In most cases this assembly will then be used in conjunction with the front plate parts numbered (1, 2, 3, 4, 5, 44). This option can be either direct or indirect reject and can also be fitted with either a single exit port or an active four way sorter.

4.3 **Top Entry**

This is achieved by adding to the basic assembly parts numbered (51, 52, 53, 55). This unit can be fitted with either a single exit port or an active four way sorter.

5.0 Coin Sorting

Coin sorting is performed by the optional four way plug in active sorter. Coin sorting is fully flexible (any coin any way) and is programmed by values STORED IN SENTINEL EEPROM IN THE COIN VALIDATOR ASSEMBLY.

There are six coin sorting functions which may each be programmed to any of the eight coin channels-

Coin always diverted down sorter path A'

Coin always diverted down sorter path B

Coin always diverted down sorter path C

Coin always diverted down sorter path D

Coin toggles alternately down sorter paths A & B

Coin toggles alternately down sorter paths C & D

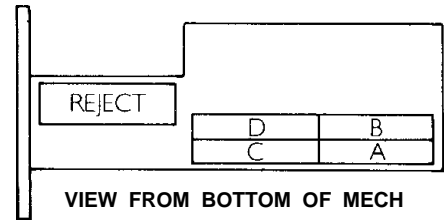

FIG 8.

The last two sorter functions are intended for club machines or any application where two pay out devices for the same coin value are required.

5.1 Coin Sorter Module

When fitted to the assembly the sorter allows four way sorting. This is achieved by two Integral flaps (27,36) which are actively driven by two solenoids(23B,23C). The first flap (36) is a metal Construction, which diverts the coin to one of the ports A or B at the back of the assembly when the solenoid(23C) is not energised, and to one of the ports C or D near the centre of the mechanism when the solenoid is energised. The long plastic diverterflap (27)which runs the length of the sorter is used to select between ports A and B or between ports C and D under the control of the solenoid (23B).

Two sets of photo cells(47) are located at the bottom of the sorter, which reset the solenoids and allow the assembly to accept further coins immediately after the coin has cleared the cells. This eliminates any timing complication.

The default path of the sorter (i.e. no solenoids energised) is path A. With reference to the sorter output paths diagram it can be seen that if a solenoid fails to operate, it will cause a coin to tend toward the A side of the sorter i.e. Top solenoid fail will cause coins from C to go down A and D to go down B. similarly if the bottom solenoid fails, coins from B will go down A, and coins from D go down C.

The sorter paths are programmed into the Sentinel validator assembly on manufacture to the customer requirements. Note that replacement of a sorter does NOT require any reprogramming, but that replacement of the complete mech MUST be with one with the same sorter paths (as shown on the mech label). The Sentinel may be reprogrammed for other coin paths using the Sentinel Toolkit.

5:2 Removal and Replacement of Sorter

The sorter can be unplugged once the cover and snubber are removed -see Mechanism Internal Access 6.0. When reassembling a sorter onto the mechanism body ensure that the diverter flap (27) does not become trapped between the sorter body and the mechanism. This is most easily ensured by offering the mechanism body down onto the sorter module. Ensure that the 4 connector pins are aligned correctly with the sockets in the mechanism body. Once the sorter is fitted correctly, refit the snubber (25) and cover (39), securing with screw (I 9C).

**ELECTRICAL
SPECIFICATION
POWER SUPPLY
REQUIREMENTS**

- 6.0 Mechanism Internal **Access**
Access to parts required for on site service is by removal of the screw (I 9C). Note the position of the metal nubber (25), and ensure that it is refitted correctly on reassembly of the mechanism.
- 7.0 Mechanism Removal and installation in Machine
To remove the body from the front plate, disconnect any serial or parallel Interface connectors Hold the mechanism across the top, and pull the locking catch (6) toward you with one finger. Raise the mechanism as far as it will go without pulling the mechanism toward you. withdraw the mechanism by pulling gently toward the rear of the machine. Note that there is no sideways movement in removing the Sentinel acceptor. Installation is the reverse of removal, except that the locking bar will engage automatically when the acceptor is properly located.
- 8.0 Electrical Interface Specifications
IMPORTANT NOTE
Application of signals or voltages outside specification may cause damage to or malfunction of the mechanism
- 8.1 Power Supply
Voltage: 1 to 15 volts DC
Current: 220 mA continuous.
0.7 A maximum (no sorter fitted)
2.0 A maximum (with sorter fitted)
Rise time: 200 msec maximum
It is important to ensure sufficient power supply current capacity. A minimum capacitance of 4700 microfarads is recommended on the machine power supply output rail.
- 8.2 Parallel Interface
COM A: +5 to +20V DC, -5 to -20V DC
200 mA maximum
A1 to A4: 8 mA source at COM A = +5V
50 mA source at COM A = +9V to +24V
20 mA sink at COM A = -5V
50 mA sink at COM A = -10V to -20V
Pulse length + 80msec +/- 20%
I1 to I7,8: Internal pull up to 5V DC
Open circuit or > 3.6V = inhibit
Short circuit to 0V or < 1.2V = accept
SELECT internal pull up to 5V
Open circuit or > 3.6V = 4 coin
Short circuit to 0V or < 1.2V = 8 coin
- 9.0 Using the Parallel Interface
The parallel Interface provides open collector output signals which will automatically sense the voltage applied to COM A and select pull up or pull down output drives as required.
All parallel interface signals are routed via connector I, and the following signals are available on this connector
- | Pin No. | Signal Name | Signal Description |
|---------|-------------|--------------------------------------|
| 1 | COM 4 | Supply input for accept output drive |
| 2 | A 1 | Accept output Coin 1 |
| 3 | NC | Polarising position |
| 4 | A2 | Accept output Coin 2 |
| 5 | A3 | Accept output Coin 3 |
| 6 | Select | 4 coin/8 Coin select line |
| 7 | A4 | Accept output Coin 4 |
| 8 | I4 | Inhibit acceptance Coin 4 |
| 9 | v supply | Power supply Input |
| 10 | 0 volts | Machine 0 volts supply |
| 11 | I3 | Inhibit acceptance Coin 3 |
| 12 | I2 | Inhibit acceptance Coin 2 |
| 13 | I1 | Inhibit acceptance Coin 1 |
| 14 | I5,6 | Inhibit acceptance Coins 5 and 6 |
| 15 | I7,8 | Inhibit acceptance Coins 7 and 8 |

**MAINTENANCE
AND FAULT
FINDING**

10.0

outine Maintenance

The plastic coin run down should be cleaned periodically Access to the run down is gained by foldingback the reject flap and removal of the screw (19C) and cover (39). Note the position the snubber (25) and ensure it is refitted correctly on reassembly. Remove the sorter module described - see COIN SORTER MODULE. Cleaning of the sorter module may then also be carried out.

The cleaning materials recommended for the Sentinel Coin acceptor are as follows:-

Mild detergents and water, using a damp cloth.

Foam cleaners providing they are not acetone based.

under no circumstances should any acetone or ketone based cleaners be used on the acceptor - sorter. Silicone spray polishes should never be used as these will reduce the static protection incorporated in the acceptor plastic

11.0

On Site Testing

before replacement of the mechanism, please check the following points-

Mechanism correctly installed in Front Plate/Back Channel. Gate assembly correctly closed

Mechanism rundown not obstructed Corns not backed up into the mechanism from underneath

Mechanism rundown is clean-see Routine Maintenance

Symptom	Investigate	Possible Cause
Mech does not work (all coins reject)	Connector	Poor contact Bent pins
	Power supply + 12V NOMINAL + 1 IV MINIMUM	Not switched on Incorrect voltage
	NOTF Supply voltage must not drop below this absolute minimum. A meter may not detect transients that may occur on acceptance of a coin Use of the Toolkit advised.	
	700mA 30 2 A 35 200mSec max	Inadequate power Power supply Rise Time too slow
	Inhibits inputs > 1.2V for ACCEPT Accept Gate	Mech inhibited Gate not free or dislocated
	Accept Channel	Obstruction in Channel
Mech takes first coin and then stops working	Parallel Interface - 20V to 0v +5v to +24v	parallel/ Interface COM A pin not connected. Voltage out of limits
	Serial Interface (If connected)	Host Machine not responding
	Power supply 11-15v	Voltage out of specification
True coin reject too often	Accept Gate	Flap not free or dislocated
	Connector	Loose
	Rundown	Dirty
	Sorter opto detectors 35 only	Failed Mech times out after 2 seconds, giving poor accept rate when coins are fed fast, but is alright when fed at 1 coin/3 seconds.
Coins stick or jam in mech	Rundown	Dirt or mechanical damage/obstruction
	Accept channel	
	Reject channel	
	Accept Gate	
	Sorter (If fitted)	
	Mounting of mech Body and/or sorter	Improperly mounted

One of the true coins always rejects	Parallel interface (if connected) < 1.2v for accept	dent or broken connection pin Wrong inhibit input voltage < 1.6V = ACCEPT
False coins in cashbox	Accept flap	Flap spring loose or flap dislocated
Coins 1" wrong cashbox	Sorter	Dirty, mechanical damage or obstruction Solenoid failure or wire broken
No accept signal	Connector Accept channel	Connector loose or broken Dirty or obstructed

If any of the defects cannot be rectified, then the mechanism should be replaced with one programmed to the same sorter paths as shown on the faulty mech label

Return the faulty acceptor to Coin Controls for repair. We do not recommend that any rectification is attempted on the main electronics assembly.

The mechanism is covered by a warranty from Coin Controls and unauthorised rectification may invalidate this warranty.

For spares and service contact Coin Controls Technical Sales Department. Telephone: 06 1 -678 0 1 1.